

XTR23

Tiltrotator 19-23 tonnes

High performance tiltrotator for excavators between 19 and 23 tonnes

Steelwrist third generation tiltrotators, introduced in 2024, have best in class tilt geometry, LockSense patented safety solution for work tool locking and OptiLube – an onboard lubrication system. These are only some of the technical developments of the third generation tiltrotators. Naturally, they have the low building height that is typical for all Steelwrist tiltrotators.

With a midsized excavator you can take on projects of varying sizes, from small scale landscaping tasks to roadwork or foundation work on construction sites. The XTR23 tiltrotator enhances the efficiency of the excavator as it enables you to rotate a work tool 360 degrees and tilt 45 degrees in each direction, with top of the class precision and controllability. This facilitates the work and makes you flexible to take on a variety of challenging new jobs.

Advanced tilt geometry ensures smooth operation for the driver

Our design minimizes cylinder spread throughout the tilt stroke, providing fluid and high-torque movement. The refined position of the tilt cylinders prevent interference with the excavator's arm, enhancing functionality and ease of use.

A leap in safety with LockSense technology

The tiltrotator features our patented LockSense technology – a state-of-the-art sensor system for secure work tool locking. The wireless design eliminates cables and connectors from being exposed to the harsh environment.

Lubrication made easy with OptiLube

The onboard OptiLube system takes care of lubrication automatically, ensuring consistent and optimal performance. The lubricant used is specially developed for Steelwrist tiltrotators and reduces friction and extends lifetime. OptiLube is integrated into the tiltrotator's control system, allowing for continuous monitoring of lubrication performance and alerts when it is time to replace the lubricant cartridge.

Modular design for upgrade to SQ/Open-S

The tiltrotator is available with interfaces following the symmetrical standard (S standard), which is the fastest growing standard internationally. Thanks to the modular design it is possible to upgrade the tiltrotator from S-type to SQ-type. Steelwrist SQ is our high performing automatic oil connection technology used to easily change and connect hydraulic work tools on the excavator. Naturally all SQ products comply with the Open-S standard.

Easy installation with the guidance app

Our intuitive mobile app simplifies the tiltrotator installation process. It provides step-by-step instructions in most languages, making setup straightforward and user-friendly.

Control system

The tiltrotator is delivered with the advanced QuantumConnect control system platform. State-of-the-art components make installation and operation of the tiltrotator easier than ever before. The platform includes the InstallMate and QuantumConnect apps, and with sophisticated connectivity the system is always up to date.

Gripper cassette with enhanced reach and functionality (option)

The downward angled 3-finger gripper extends the reach of your excavator. With its improved geometry it gives you wide opening and near-complete closure, and it handles objects with unmatched precision. The robust design, including sturdy cylinder covers, ensures smooth operation in all your jobs.



🔧 Technical specification

Tiltrotator	XTR23	XTR23	XTR23	XTR23
Machine Interface	SQ65	S70	SQ70	SQ70/55
Tiltrotator Quick Coupler	SQ65	S70	SQ70	SQ70/55
Machine weight [ton]	19-23	19-23	19-23	19-23
Max Breakout torque [kNm]	240	240	240	240
Weight from [kg]	608	834	842	975
Gripper weight [kg]	199	199	199	143
Building height [mm]	581	585	585	613
Length [mm]	870	911	911	911
Cylinder width [mm]	798	875	858	1004
Height cylinder [mm]	496	487	487	443
Max tilt angle [degrees]	±45	±45	±45	±45
Max width dipper arm [mm]	-	-	-	-
Pin diameter [mm]	-	-	-	-
Pin distance [cc-measure] [mm]	-	-	-	-
Tilt Torque [kNm]	47	47	47	47
Rotational Torque [kNm]	11,4	11,4	11,4	11,4
Hydraulic AUX with gripper	1	1	1	1
Hydraulic AUX without gripper	2	2	2	2
Lifting hook [ton]	-	-	-	-
Oil Flow [l/min]	100	100	100	100
Max pressure [bar]	220	220	220	220
Max Pressure Separate AUX [bar]	350	350	350	350
Safety solution	LockSense	LockSense	LockSense	LockSense

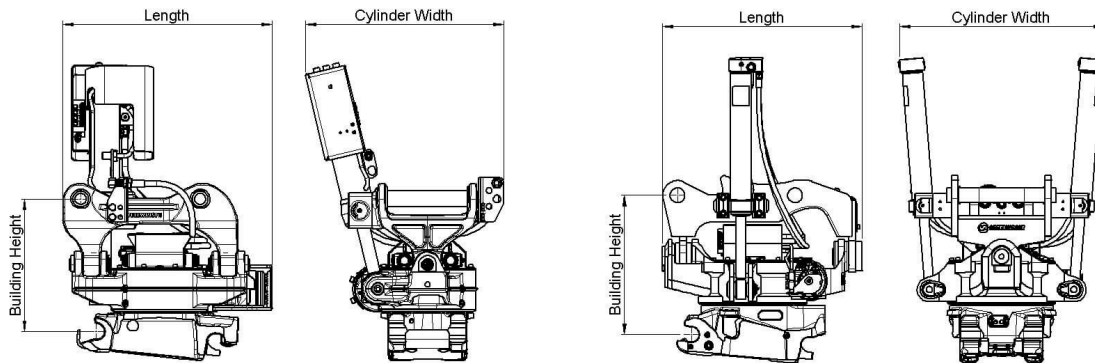

Work tools and Open-S – the world industry standard for fully automatic quick couplers



The Symmetrical Quick Coupler standard for excavators (the S-Standard) is an industry standard that was originally defined in 2006 by the Swedish Trade Association for Suppliers of Mobile Machines.

In order to achieve interchangeability the request for a standardized and well-defined interface is therefore apparent.

The Symmetrical standard, which is an open standard not controlled by one specific manufacturer, has since its inception grown to become a well-known coupler standard on the international market. The demand for quick couplers with integrated hydraulic couplings and electrical connectors, so called Fully Automatic Quick Couplers continue to grow.

As fully Automatic Quick Couplers have more intricate functions than a standard Mechanical Quick Coupler it is crucial that also non hydraulic work tools include certain features such as hardened shafts and cover plates etc. The purpose of this document is to define the technical dimensions for mechanical (non fully hydraulic) work tools to be used with Open-S Quick Couplers.

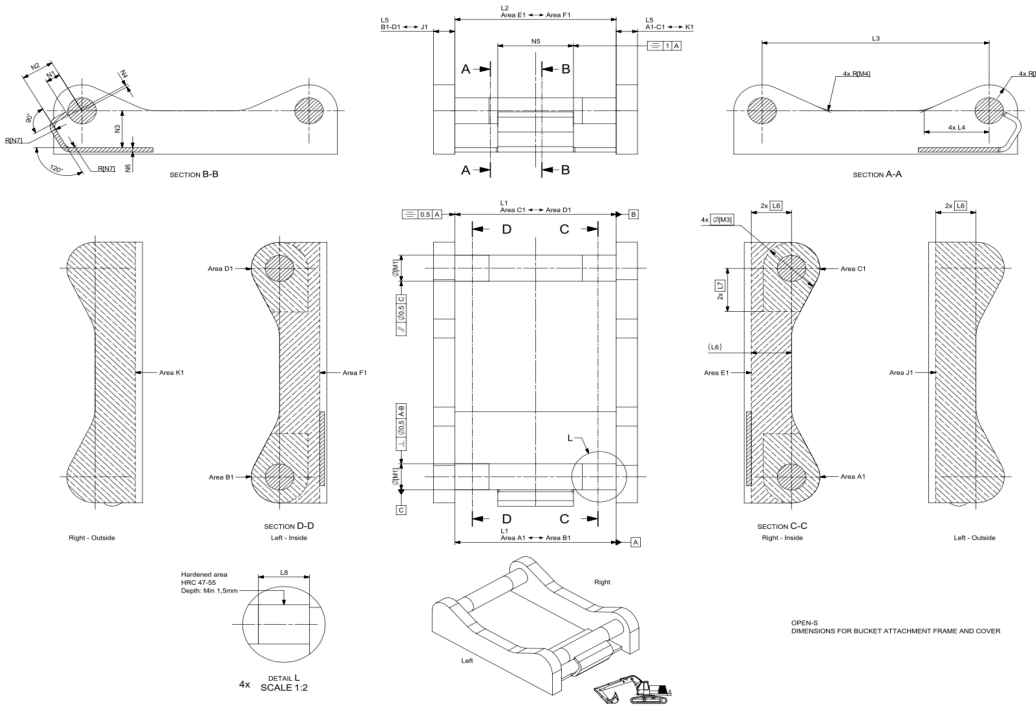

OPEN-S DIMENSIONS FOR BUCKET ATTACHMENT FRAME AND COVER

	L1 Width	L2 C. Width	L3 C-C	L4	L5 Thicken.	L6 Tol. area	L7 Tol. area	L8 Hardening	M1 Shaft D	M2 Radius	M3 Tol Area	M4	N1	N2	N3	N4 Offset	N5 Width	N6 Rec Th.	N7 Radius
OS45M	291.5 +1/-0.5	291 Min	430.25 +/-0.25	100 +/-2	40 Max	70	85	60 Min	45 f8	45 Max	90	30 +/-2	23.5 +/-1	65 +/-1	70 Min	8 +/-1	140 +/-1	8	15 Max
OS50M	271.5 +1/-0.5	271 Min	430.25 +/-0.25	100 +/-2	40 Max	70	85	70 Min	50 f8	45 Max	90	30 +/-2	26 +/-1	65 +/-1	70 Min	8 +/-1	140 +/-1	8	15 Max
OS60M	341.5 +1/-0.5	341 Min	480.25 +/-0.25	137.5 +/-2	45 Max	85	100	75 Min	60 f8	60 Max	120	30 +/-2	31 +/-1	70 +/-1	85 Min	6 +/-1	160 +/-1	10	20 Max
OS65M	441.5 +1/-0.5	441 Min	530.25 +/-0.25	152.5 +/-2	55 Max	90	110	90 Min	65 f8	65 Max	130	30 +/-2	33.5 +/-1	83 +/-1	90 Min	6 +/-1	230 +/-1	10	20 Max
OS70M	451.5 +1/-0.5	451 Min	600.25 +/-0.25	205 +/-2	55 Max	115	115	95 Min	70 f8	75 Max	150	50 +/-2	36 +/-1	90 +/-1	115 Min	7 +/-1	225 +/-1	12	30 Max
OS70/55M	551.5 +1/-0.5	551 Min	600.25 +/-0.25	205 +/-2	55 Max	115	115	95 Min	70 f8	75 Max	150	50 +/-2	36 +/-1	102 +/-1	115 Min	5 +/-1	320 +/-1	12	30 Max
OS80M	591.5 +1/-0.5	591 Min	670.25 +/-0.25	220 +/-2	65 Max	135	135	120 Min	80 f8	90 Max	180	50 +/-2	41 +/-1	110 +/-1	135 Min	8 +/-1	310 +/-1	15	30 Max
OS90M	751.5 +1/-0.5	751 Min	750.25 +/-0.25	225 +/-2	80 Max	155	150	160 Min	90 f8	110 Max	220	50 +/-2	46 +/-1	130 +/-1	155 Min	2 +/-1	400 +/-1	15	30 Max

Standardization by the Open-S Alliance. Revision A, May 17, 2021 | For more information please see www.opens.org