

XTR2

Tiltrotator 0-2 ton

A tiltrotator for the smallest excavators

Steelwrist small tiltrotators are developed with a focus on flexibility, building height and low weight that is so important for compact excavators. The XTR2 is positioned between the smallest TCX tilt coupler for machines below 2 tonnes and the X04 tiltrotator for excavators from 2,5 to 4 tonnes. A compact excavator with a tiltrotator is a good choice for construction work at busy and confined sites in the city, with workers and citizens on the move nearby. The tiltrotator brings more manoeuvrability in a sensitive area, while delivering excellent earthmoving capacities and efficiency for the excavator.

The XTR2 tiltrotator has a number of innovative design solutions and comes with either a Direct Fit or an S30 top for the connection to the excavator. The coupler side (bottom) of the tiltrotator is available in a hydraulic locking for S30. The hydraulic lock version with the integrated Front Pin Hook is probably the only tiltrotator in this class that has work tool safety to support CE requirements. A Direct Fit configuration is often chosen for compact excavators, where the tiltrotator is permanently mounted to the dipper arm.

Optimized range of work tools

With a complete set of Steelwrist S30 work tools for the XTR2 tiltrotator, such as grading-, digging-, cable/trenching- and v-ditch bucket, multi grapple, asphalt cutter and ripper, the excavator turns into an efficient and versatile tool carrier that can do work in a wide range of applications.

Control systems

Steelwrist supply two types of tiltrotator control system. The QuantumConnect platform with state-of-the-art components makes installation and operation of the tiltrotator easier than ever before. The platform includes the InstallMate and QuantumConnect apps, and with sophisticated connectivity the system is always up to date. The four hose proportional machine control is the more basic system.



🔧 Technical specification

Tiltrotator	XTR2	XTR2		
Machine Interface	S30	DF		
Tiltrotator Quick Coupler	S30	S30		
Machine weight [ton]	0-2	0-2		
Max Breakout torque [kNm]	28	28		
Weight from [kg]	80	80		
Building height [mm]	273	273		
Length [mm]	444	444		
Cylinder width [mm]	367	335		
Height cylinder [mm]	230	230		
Max tilt angle [degrees]	±40	±40		
Max width dipper arm [mm]	–	125		
Pin diameter [mm]	–	25-35		
Pin distance [cc-measure] [mm]	–	85-185		
Tilt Torque [kNm]	4,7	4,7		
Rotational Torque [kNm]	1,4	1,4		
Hydraulic AUX with gripper	–	–		
Hydraulic AUX without gripper	1	1		
Lifting hook [ton]	–	0,75		
Oil Flow [l/min]	20	20		
Max pressure [bar]	210	210		
Max Pressure Separate AUX [bar]	–	–		
Safety solution	FPH	FPH		

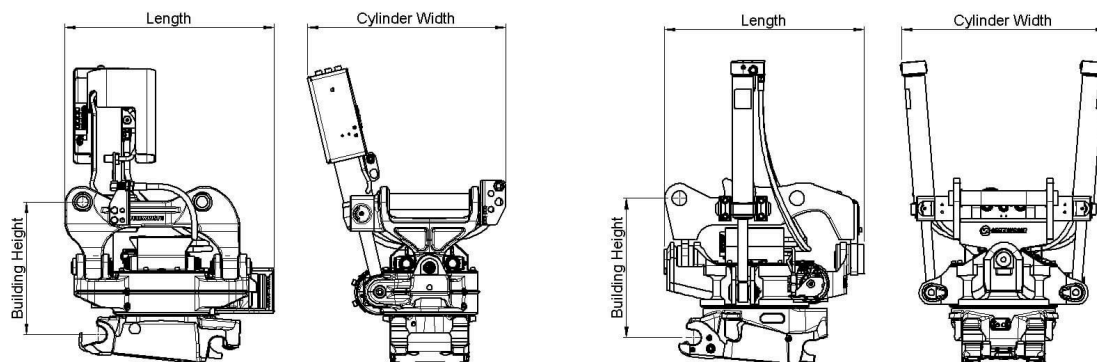

Work tools and Open-S – the world industry standard for fully automatic quick couplers



The Symmetrical Quick Coupler standard for excavators (the S-Standard) is an industry standard that was originally defined in 2006 by the Swedish Trade Association for Suppliers of Mobile Machines.

In order to achieve interchangeability the request for a standardized and well-defined interface is therefore apparent.

The Symmetrical standard, which is an open standard not controlled by one specific manufacturer, has since its inception grown to become a well-known coupler standard on the international market. The demand for quick couplers with integrated hydraulic couplings and electrical connectors, so called Fully Automatic Quick Couplers continue to grow.

As fully Automatic Quick Couplers have more intricate functions than a standard Mechanical Quick Coupler it is crucial that also non hydraulic work tools include certain features such as hardened shafts and cover plates etc. The purpose of this document is to define the technical dimensions for mechanical (non fully hydraulic) work tools to be used with Open-S Quick Couplers.



OPEN-S DIMENSIONS FOR BUCKET ATTACHMENT FRAME AND COVER

	L1 Width	L2 C. Width	L3 C-C	L4	L5 Thicken.	L6 Tol. area	L7 Tol. area	L8 Hardening	M1 Shaft D	M2 Radius	M3 Tol Area	M4	N1	N2	N3	N4 Offset	N5 Width	N6 Rec Th.	N7 Radius
OS45M	291.5 +1/-0.5	291 Min	430.25 +/-0.25	100 +/-2	40 Max	70	85	60 Min	45 f8	45 Max	90	30 +/-2	23.5 +/-1	65 +/-1	70 Min	8 +/-1	140 +/-1	8	15 Max
OS50M	271.5 +1/-0.5	271 Min	430.25 +/-0.25	100 +/-2	40 Max	70	85	70 Min	50 f8	45 Max	90	30 +/-2	26 +/-1	65 +/-1	70 Min	8 +/-1	140 +/-1	8	15 Max
OS60M	341.5 +1/-0.5	341 Min	480.25 +/-0.25	137.5 +/-2	45 Max	85	100	75 Min	60 f8	60 Max	120	30 +/-2	31 +/-1	70 +/-1	85 Min	6 +/-1	160 +/-1	10	20 Max
OS65M	441.5 +1/-0.5	441 Min	530.25 +/-0.25	152.5 +/-2	55 Max	90	110	90 Min	65 f8	65 Max	130	30 +/-2	33.5 +/-1	83 +/-1	90 Min	6 +/-1	230 +/-1	10	20 Max
OS70M	451.5 +1/-0.5	451 Min	600.25 +/-0.25	205 +/-2	55 Max	115	115	95 Min	70 f8	75 Max	150	50 +/-2	36 +/-1	90 +/-1	115 Min	7 +/-1	225 +/-1	12	30 Max
OS70/55M	551.5 +1/-0.5	551 Min	600.25 +/-0.25	205 +/-2	55 Max	115	115	95 Min	70 f8	75 Max	150	50 +/-2	36 +/-1	102 +/-1	115 Min	5 +/-1	320 +/-1	12	30 Max
OS80M	591.5 +1/-0.5	591 Min	670.25 +/-0.25	220 +/-2	65 Max	135	135	120 Min	80 f8	90 Max	180	50 +/-2	41 +/-1	110 +/-1	135 Min	8 +/-1	310 +/-1	15	30 Max
OS90M	751.5 +1/-0.5	751 Min	750.25 +/-0.25	225 +/-2	80 Max	155	150	160 Min	90 f8	110 Max	220	50 +/-2	46 +/-1	130 +/-1	155 Min	2 +/-1	400 +/-1	15	30 Max

Standardization by the Open-S Alliance. Revision A, May 17, 2021 | For more information please see www.opens.org

