

# XR7

## Rotor coupler 4-7 tonnes

---



### Rotor coupler for excavators between 4 and 7 tonnes

Steelwrist rotor couplers bring a new level of versatility and precision compared to a standard coupler. The flexibility provided by the XR7 rotor coupler turns also the compact excavator into a true tool carrier, able to take on a variety of tasks and maximizing the utilization of the machine. Designed to perform, our robust gearbox allows for precise and efficient rotation of any work tool.

Whether it is road construction, shaping embankments or digging trenches, our rotor couplers enhance the flexibility and productivity of your excavator. The XR7 rotor coupler is available with interfaces following the symmetrical standard (S standard), which is the fastest growing standard internationally.



#### Compact design and easy installation

Steelwrist XR7 rotor coupler has a robust design and still a low building height and weight. Installation is fast and easy as no separate control system is required. The machine needs to be equipped with minimum one dual connection auxiliary line, and an additional auxiliary line can be used to operate the gripper unit (option) or a hydraulic work tool under the rotor coupler.

#### High flow swivel joint for enhanced capabilities

Our rotor couplers have high flow swivel joints, enabling the use of high flow-demanding work tools such as hydraulic breakers, compactors and grapples. The high flow swivel design ensures maximum flow efficiency, allowing your work tools to perform at their best.

#### Front Pin Hook safety solution

The coupler has Front Pin Hook for safe work tool changes, a robust and secure solution, compliant with safety regulations.

#### Gripper cassette (option)

An integrated gripper is an amazing tool that increases your productivity even further. The gripper opens widely, closes almost entirely, has robust cylinder covers and does not interfere with excavation. Of course, it can be retrofitted.

#### Absolute rotation sensor (option)

Upgrade your coupler with an Absolute rotation sensor for improved accuracy, control and integration with Machine Control Systems (MCS).

## Teknisk specifikation

Quick coupler	S40
Machine weight [ton]	4-7
Max Breakout torque [kNm]	65
Weight from [kg]	130
Building height [mm]	272
Length [mm]	610
Max width dipper arm [mm]	200
Pin diameter [mm]	35-50
Pin distance [cc-measure] [mm]	160-310
Rotational Torque [kNm]	5,2
Hydraulic AUX with gripper	1
Hydraulic AUX without gripper	1
Lifting hook [ton]	2
Oil Flow [l/min]	30
Max pressure [bar]	210
Max Pressure Separate AUX [bar]	350
Safety solution	FPH

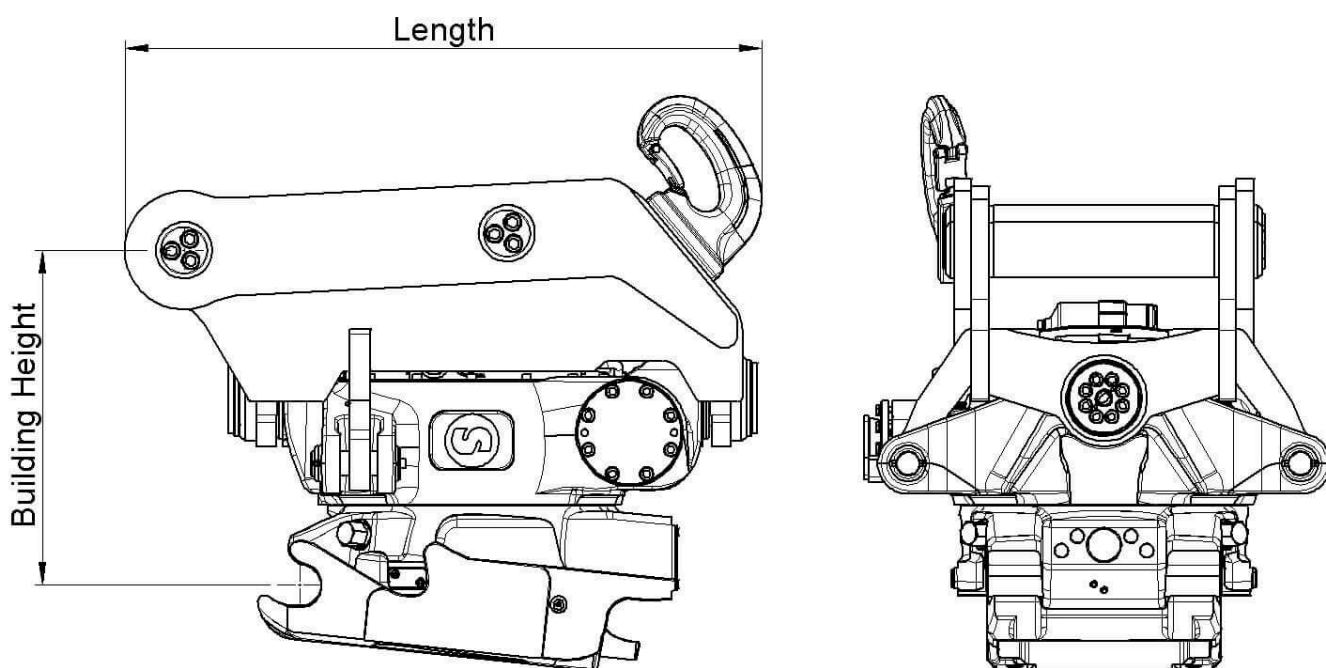

# S-Standard

## Symmetrical Quick Couplers for Excavators (S-standard)

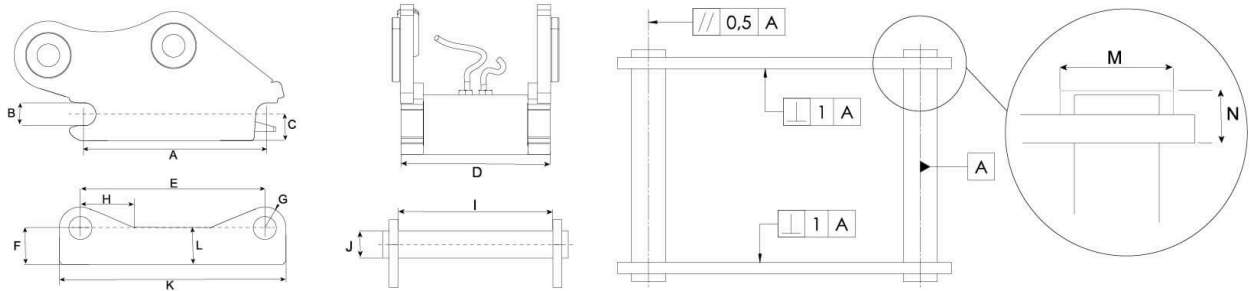

Dimensions and tolerance table

Measurements (mm)	S30 /150	S30 /180	S40	S40 /240	S45	S50	S60	S70	S80	S90 /620	S90 /750	S100	S120
A	199,8 ±0,2	229,8 ±0,2	299,8 ±0,2	299,8 ±0,2	429,8 ±0,2	429,8 ±0,2	479,8 ±0,2	599,8 ±0,2	669,8 ±0,2	749,8 ±0,2	749,8 ±0,2	899,8 ±0,2	924,8 ±0,2
B	30 H9	30 H9	40 H9	40 H9	45 H9	50 H9	60 H9	70 H9	80 H9	90 H9	90 H9	100 H9	120 H9
C	Max 40	Max 45	Max 50	Max 50	Max 65	Max 65	Max 80	Max 100	Max 115	Max 125	Max 125	Max 150	Max 200
D	148 ±1	178 ±1	198 ±1	238 ±1	288 ±1	268 ±1	338 ±1	448 ±1	568 ±1	618 ±1	748 ±1	748 ±1	868 ±1
E	200,5 ±0,5	230,5 ±0,5	300,5 ±0,5	300,5 ±0,5	430,5 ±0,5	430,5 ±0,5	480,5 ±0,5	600,5 ±0,5	670,5 ±0,5	750,5 ±0,5	750,5 ±0,5	900,5 ±0,5	925,5 ±0,5
F	Min 45	Min 50	Min 55	Min 55	Min 70	Min 70	Min 85	Min 115	Min 135	Min 155	Min 155	Min 175	Min 240
G	Max 30	Max 30	Max 40	Max 40	Max 45	Max 45	Max 60	Max 75	Max 90	Max 110	Max 110	Max 125	Max 145
H	Max 85	Max 85	Max 100	Max 100	Max 125	Max 125	Max 150	Max 250	Max 250	Max 250	Max 250	Max 250	Max 250
I	152 ±1	182 ±1	202 ±1	242 ±1	292 ±1	272 ±1	342 ±1	452 ±1	592 ±1	622 ±1	752 ±1	752 ±1	872 ±1
J	30 f8	30 f8	40 f8	40 f8	45 f8	50 f8	60 f8	70 f8	80 f8	90 f8	90 f8	100 f8	120 f8
K	Max 260	Max 290	Max 380	Max 380	Max 520	Max 520	Max 600	Max 740	Max 830	Max 1000	Max 1000	Max 1150	Max 1250
L	Max 45	Max 50	Max 55	Max 55	Max 70	Max 70	Max 85	Max 115	Max 135	Max 200	Max 200	Max 250	Max 300
M	Max 62	Max 62	Max 72	Max 72	Max 77	Max 77	Max 92	Max 102	Max 122	Max 132	Max 132	Max 142	Max 162
N	Max 25	Max 25	Max 28	Max 28	Max 30	Max 30	Max 35	Max 40	Max 55	Max 70	Max 70	Max 75	Max 80

Load table

Quick Coupler Size	Width (mm)	Shaft c-c (mm)	Shaft diameter (mm)	Minimum Positive Torque (kNm)	Minimum Negative Torque (kNm)	Max recommended machine weight (ton)
S30/150	150	200	30	28	20	2
S30/180	180	230	30	28	20	2
S40	200	300	40	35	23	6
S40/240	240	300	40	40	26	7
S45	290	430	45	65	42	11
S50	270	430	50	65	42	11
S60	340	480	60	150	75	18
S70	450	600	70	300	195	30
S80	590	670	80	600	390	40
S90/620	620	750	90	1000	650	70
S90/750	750	750	90	1000	650	70
S100	750	900	100	1200	775	85
S120	925	870	120	1600	1000	100



# Work tools and Open-S – the world industry standard for fully automatic quick couplers



The Symmetrical Quick Coupler standard for excavators (the S-Standard) is an industry standard that was originally defined in 2006 by the Swedish Trade Association for Suppliers of Mobile Machines.

The Symmetrical standard, which is an open standard not controlled by one specific manufacturer, has since its inception grown to become a well-known coupler standard on the international market. The demand for quick couplers with integrated hydraulic couplings and electrical connectors, so called Fully Automatic Quick Couplers continue to grow.

In order to achieve interchangeability the request for a standardized and well-defined interface is therefore apparent.

As fully Automatic Quick Couplers have more intricate functions than a standard Mechanical Quick Coupler it is crucial that also non hydraulic work tools include certain features such as hardened shafts and cover plates etc. The purpose of this document is to define the technical dimensions for mechanical (non fully hydraulic) work tools to be used with Open-S Quick Couplers.

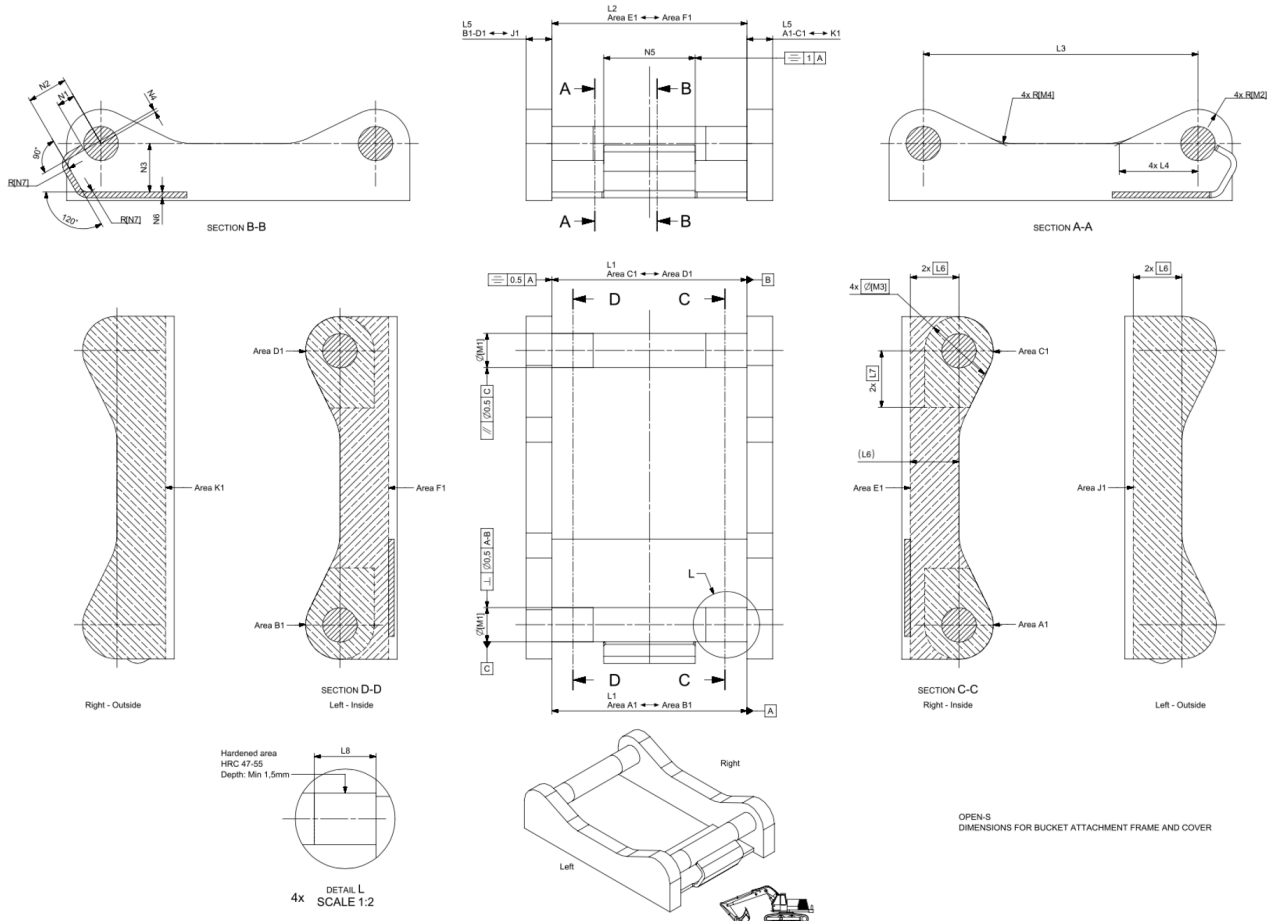

OPEN-S DIMENSIONS FOR BUCKET ATTACHMENT FRAME AND COVER

	L1 Width	L2 C. Width	L3 C-C	L4	L5 Thickn.	L6 Tot. area	L7 Tot. area	L8 Hardening	M1 Shaft D	M2 Radius	M3 Tot Area	M4	N1	N2	N3	N4 Offset	N5 Width	N6 Rec Th.	N7 Radius
<b>OS45M</b>	291,5 +1/-0,5	291 Min	430,25 +/-0,25	100 +/-2	40 Max	70	85	60 Min	45 f8	45 Max	90	30 +/-2	23,5 +/-1	65 +/-1	70 Min	8 +/-1	140 +/-1	8	15 Max
<b>OS50M</b>	271,5 +1/-0,5	271 Min	430,25 +/-0,25	100 +/-2	40 Max	70	85	70 Min	50 f8	45 Max	90	30 +/-2	26 +/-1	65 +/-1	70 Min	8 +/-1	140 +/-1	8	15 Max
<b>OS60M</b>	341,5 +1/-0,5	341 Min	480,25 +/-0,25	137,5 +/-2	45 Max	85	100	75 Min	60 f8	60 Max	120	30 +/-2	31 +/-1	70 +/-1	85 Min	6 +/-1	160 +/-1	10	20 Max
<b>OS65M</b>	441,5 +1/-0,5	441 Min	530,25 +/-0,25	152,5 +/-2	55 Max	90	110	90 Min	65 f8	65 Max	130	30 +/-2	33,5 +/-1	83 +/-1	90 Min	6 +/-1	230 +/-1	10	20 Max
<b>OS70M</b>	451,5 +1/-0,5	451 Min	600,25 +/-0,25	205 +/-2	55 Max	115	115	95 Min	70 f8	75 Max	150	50 +/-2	36 +/-1	90 +/-1	115 Min	7 +/-1	225 +/-1	12	30 Max
<b>OS70/55M</b>	551,5 +1/-0,5	551 Min	600,25 +/-0,25	205 +/-2	55 Max	115	115	95 Min	70 f8	75 Max	150	50 +/-2	36 +/-1	102 +/-1	115 Min	5 +/-1	320 +/-1	12	30 Max
<b>OS80M</b>	591,5 +1/-0,5	591 Min	670,25 +/-0,25	220 +/-2	65 Max	135	135	120 Min	80 f8	90 Max	180	50 +/-2	41 +/-1	110 +/-1	135 Min	8 +/-1	310 +/-1	15	30 Max
<b>OS90M</b>	751,5 +1/-0,5	751 Min	750,25 +/-0,25	225 +/-2	80 Max	155	150	160 Min	90 f8	110 Max	220	50 +/-2	46 +/-1	130 +/-1	155 Min	2 +/-1	400 +/-1	15	30 Max

Standardization by the Open-S Alliance. Revision A, May 17, 2021 | For more information please see [www.opens.org](http://www.opens.org)