

X26

Tiltrotator 18-26 tonnes



A tiltrotator for excavators between 18 and 26 tonnes

The Steelwrist X26 tiltrotator is designed to deliver the power and durability that is a must for excavators of this size. Our tiltrotators have a low building height, high tilt angle and an unbeatable relationship between strength and weight thanks to steel cast components.

A tiltrotator for the heavy-duty tasks

Our X26 tiltrotator is perfect for heavy-duty tasks in road work, foundation digging, earthmoving and demolition in large construction projects. The X26 tiltrotator enhances the efficiency of the excavator as it enables you to rotate a work tool 360 degrees and tilt 45 degrees in each direction, with top of the class precision and controllability. This facilitates your work and makes you flexible to take on a variety of challenging new jobs.

Steelwrist quick couplers and tiltrotators follow the symmetrical standard (S-standard), the fastest growing coupler type internationally. The attachment coupler on the tiltrotator has Front Pin Lock (FPL) safety solution, a mechanical lock of the front shaft which significantly limits the risk of an unintended drop of work tools. The tiltrotator is delivered with a control system that fits your excavator regardless if you need a two or four hose solution. With a tiltrotator that has high flow hydraulics you will be able to use the tiltrotator in a more fuel efficient way and it allows for efficient use of high flow work tools. A robust and easily calibrated Absolute Rotation sensor in the high flow swivel gives high accuracy data to Machine Control Systems.

A Sandwich configuration is often chosen for this size of excavators. This means that a quick coupler is mounted on the excavator arm, making it possible to disconnect the tiltrotator and pick up and connect a work tool directly.

Steelwrist SQ auto connection system and the Open-S standard

Steelwrist SQ is our high performing automatic oil connection technology used to easily change and connect hydraulic work tools on the excavator. All SQ products comply with the Open-S standard. This means that the SQ system is designed to be able to connect to other brands following the Open-S standard. S-type tiltrotators (from S50 and up) are upgradeable to SQ-type at a later stage.

Control system

Steelwrist supply two types of tiltrotator control system. The QuantumConnect platform with state-of-the-art components makes installation and operation of the tiltrotator easier than ever before. The platform includes the InstallMate and QuantumConnect apps, and with sophisticated connectivity the system is always up to date. The four hose proportional machine control is the more basic system.

Gripper cassette (option)

Equip the tiltrotator with a gripper cassette with a finger gripper that will make your excavator even more flexible, handling objects with precision. The gripper cassette can be retrofitted.

Central lubrication (option)

Our tiltrotators can be equipped directly from factory with central lubrication that fits all central lubrication systems on the market.

The X26 tiltrotator is also available with Verachttert (CW) or Lehnhoff (HS) coupler interface. For Verachttert (CW) the tiltrotator always has a Direct fit configuration.



🔧 Technical specification

Tiltrotator	X26	X26	X26	X26	X26	X26
Machine Interface	S70	SQ70	SQ70/55	DF	DF	DF
Tiltrotator Quick Coupler	S70	SQ70	SQ70/55	S70	SQ70	SQ70/55
Machine weight [ton]	18-26	18-26	18-26	18-26	18-26	18-26
Max Breakout torque [kNm]	240	240	240	240	240	240
Weight from [kg]	695	695	695	695	695	695
Gripper weight [kg]	140	140	140	140	140	140
Building height [mm]	615	615	615	640	640	640
Length [mm]	823	823	823	891	891	891
Cylinder width [mm]	845	845	1042	871	871	871
Maximum tilt angle [degrees]	±45	±45	±45	±45	±45	±45
Max width dipper arm [mm]	-	-	-	350	350	350
Pin diameter [mm]	-	-	-	60-90	60-90	60-90
Pin distance [cc-measure] [mm]	-	-	-	380-485	380-485	380-485
Tilt Torque [kNm]	61	61	61	61	61	61
Rotational Torque [kNm]	8,8	8,8	8,8	8,8	8,8	8,8
Hydraulic AUX with gripper	1	1	1	1	1	1
Hydraulic AUX without gripper	2	2	2	2	2	2
Lifting hook [ton]	-	-	-	8	8	8
Oil Flow [l/min]	113	113	113	113	113	113
Max pressure [bar]	210	210	210	210	210	210
Max Pressure Separate AUX [bar]	350	350	350	350	350	350
Safety solution	FPL	FPL	LockSense	FPL	FPL	LockSense

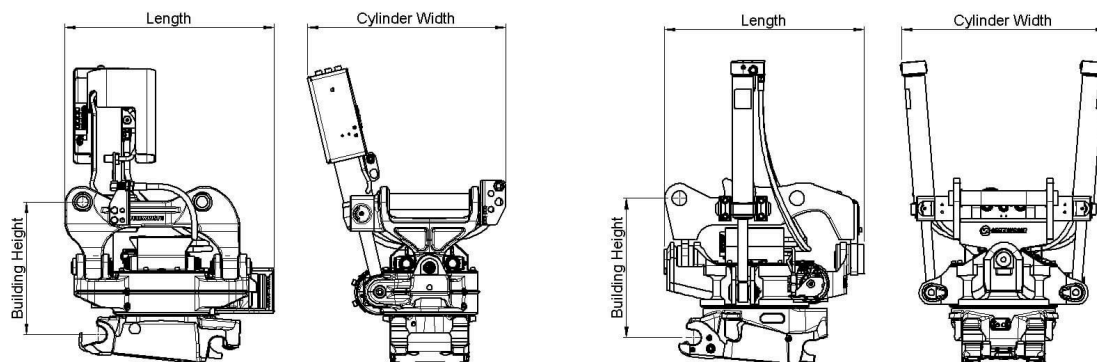

Work tools and Open-S – the world industry standard for fully automatic quick couplers



The Symmetrical Quick Coupler standard for excavators (the S-Standard) is an industry standard that was originally defined in 2006 by the Swedish Trade Association for Suppliers of Mobile Machines.

In order to achieve interchangeability the request for a standardized and well-defined interface is therefore apparent.

The Symmetrical standard, which is an open standard not controlled by one specific manufacturer, has since its inception grown to become a well-known coupler standard on the international market. The demand for quick couplers with integrated hydraulic couplings and electrical connectors, so called Fully Automatic Quick Couplers continue to grow.

As fully Automatic Quick Couplers have more intricate functions than a standard Mechanical Quick Coupler it is crucial that also non hydraulic work tools include certain features such as hardened shafts and cover plates etc. The purpose of this document is to define the technical dimensions for mechanical (non fully hydraulic) work tools to be used with Open-S Quick Couplers.



OPEN-S DIMENSIONS FOR BUCKET ATTACHMENT FRAME AND COVER

	L1 Width	L2 C. Width	L3 C-C	L4	L5 Thickn.	L6 Tot. area	L7 Tot. area	L8 Hardening	M1 Shaft D	M2 Radius	M3 Tot Area	M4	N1	N2	N3	N4 Offset	N5 Width	N6 Rec Th.	N7 Radius
OS45M	291.5 +1/-0.5	291 Min	430.25 +/-0.25	100 +/-2	40 Max	70	85	60 Min	45 f8	45 Max	90	30 +/-2	23.5 +/-1	65 +/-1	70 Min	8 +/-1	140 +/-1	8	15 Max
OS50M	271.5 +1/-0.5	271 Min	430.25 +/-0.25	100 +/-2	40 Max	70	85	70 Min	50 f8	45 Max	90	30 +/-2	26 +/-1	65 +/-1	70 Min	8 +/-1	140 +/-1	8	15 Max
OS60M	341.5 +1/-0.5	341 Min	480.25 +/-0.25	137.5 +/-2	45 Max	85	100	75 Min	60 f8	60 Max	120	30 +/-2	31 +/-1	70 +/-1	85 Min	6 +/-1	160 +/-1	10	20 Max
OS65M	441.5 +1/-0.5	441 Min	530.25 +/-0.25	152.5 +/-2	55 Max	90	110	90 Min	65 f8	65 Max	130	30 +/-2	33.5 +/-1	83 +/-1	90 Min	6 +/-1	230 +/-1	10	20 Max
OS70M	451.5 +1/-0.5	451 Min	600.25 +/-0.25	205 +/-2	55 Max	115	115	95 Min	70 f8	75 Max	150	50 +/-2	36 +/-1	90 +/-1	115 Min	7 +/-1	225 +/-1	12	30 Max
OS70/55M	551.5 +1/-0.5	551 Min	600.25 +/-0.25	205 +/-2	55 Max	115	115	95 Min	70 f8	75 Max	150	50 +/-2	36 +/-1	102 +/-1	115 Min	5 +/-1	320 +/-1	12	30 Max
OS80M	591.5 +1/-0.5	591 Min	670.25 +/-0.25	220 +/-2	65 Max	135	135	120 Min	80 f8	90 Max	180	50 +/-2	41 +/-1	110 +/-1	135 Min	8 +/-1	310 +/-1	15	30 Max
OS90M	751.5 +1/-0.5	751 Min	750.25 +/-0.25	225 +/-2	80 Max	155	150	160 Min	90 f8	110 Max	220	50 +/-2	46 +/-1	130 +/-1	155 Min	2 +/-1	400 +/-1	15	30 Max

Standardization by the Open-S Alliance. Revision A, May 17, 2021 | For more information please see www.opens.org