



STEELWRIST

EARTHMOVING EFFICIENCY



Steelwrist SQ
Fully Automatic Quick Coupler Systems

COMMITMENT TO EFFICIENCY

Responsiveness, Simplicity and Speed

Steelwrist is today a global manufacturer of tiltrotators, quick couplers and work tools for excavators with headquarters in Sweden. Since the foundation in 2005, Steelwrist has been one of the fastest growing industrial companies in the industry.

Our core values of Responsiveness, Simplicity and Speed guide the way for how we work with customers, dealers, suppliers and employees. We listen to and learn together with our customers, we are easy to work with and we focus on delivering

value with speed – everything being at the core of our company culture.

Steelwrist's goal is to be the "best in the world to develop, manufacture and sell equipment that increases efficiency of excavators" and a determined focus on robust and modern products, combined with fast service are appreciated by an increasing number of customers world wide.

TABLE OF CONTENTS

04. Open-S - The new global standard

06. SQ Auto Connection System

08. SQ Adaptors

10. SQ for general construction

12. SQ for demolition and recycling

14. SQ size and connections, dimensions and locations

16. Technical information

The key to unlock your excavator efficiency

Enablers and Automation

The core of the Steelwrist product offering includes quick couplers, tilt couplers and tiltrotators that together with the control system make up the foundation for higher excavator efficiency.

Regardless if your need is a safe and robust quick coupler, a more advanced tilt coupler, or the most efficient tiltrotator, we have the solution for you.

We introduced the patented Front Pin Lock technology already in 2012 which pushed the industry to focus more on safe quick couplers. Since then we have introduced solutions that increase safety even further.

Our SQ technology will convert the quick couplers and tiltrotators to automatic quick coupler systems connecting both hydraulics and electrical signals in one movement. No need to get out of the cabin for any tool change.

Work Tools

A job needs a work tool and a work tool needs an excavator - not the other way around. That's the starting point when we think about how to increase your excavator efficiency.

Steelwrist work tools include buckets such as grading-, digging-, cable-, v-ditch-, sorting-, skeleton- and utility buckets as well as rippers, pallet forks, asphalt cutters and grading beams.

Our powered work tools include a range of multi-, sorting- and finger grapples as well as sweepers and compactors.



04



OPEN-S - THE GLOBAL STANDARD

A good solution for machine owner and industry

Open-S is the open standard for fully automatic quick couplers for excavators. The goal is to give machine operators and contractors around the world the freedom to combine quick couplers, tiltrotators and work tools from manufacturers that are in compliance with the standard, and to promote continued technological development.

Open-S is owned and managed by an independent organization, Open-S Alliance, and builds on the independent and established standard that already exists for quick couplers - the S standard. Steelwrist is a full member of the Open-S Alliance.

Freedom to choose and combine

With an open standard for quick couplers, machine operators and contractors can more easily choose quick couplers, tiltrotators and work tools from different manufacturers, and be confident that they will function together. The standard also means that dealers can provide clearer information about which products fit together.

Technological development

With a common standard it is easier for industry manufacturers to continue to compete with performance and functionality, and still offer customers compatibility.

Safety first

Reducing the risk of accidents and incidents is a priority and in recent years major and important advances have been made in terms of product and operator safety. With Open-S you can be more confident that these solutions will continue to work. The open interface defines hydraulic couplers and ensures that a combination of products from different manufacturers will not in any way interfere with or alter the safety solution of each individual product.



OPEN | **OS**

Open-S - the open industry standard for fully automatic quick couplers.

Read more at www.opens.org

OPEN STANDARD

Open-S strives to give the machine owner the freedom to choose what solution to buy and the manufacturers to focus on developing features that enhance performance and functionality of their products.



The future is open!
Read more at opens.org



06



STEELWRIST SQ AUTO CONNECTION SYSTEM

Changing powered work tools in seconds

The demand for productivity is constantly rising and in some applications the need for quick tool changes is almost continuous. With Steelwrist SQ technology you change between hydraulic powered work tools as well as mechanical work tools in only seconds – all without leaving the cab! In 2017 we introduced our patented Qplus™ technology which radically changes the "inside" of the hydraulic couplings. With the introduction of SQ50 the Qplus technology has been updated to allow for even higher flows, adding another 20 percent to flow capacity which allows users to run also the high flow requiring work tools on mid size excavators.

We believe in open standard interfaces, so the SQ system is designed to be able to connect to other brands following the Open-S standard.

Steelwrist Qplus™

is the label we have put on all the improvements we have developed compared to competitor solutions. Higher flow, more uptime and improved serviceability are the main benefits for the operator.

Qplus™ - Higher flow!

With Steelwrist Qplus™ the flow area measure up to 37 percent more compared to competitor products (depending on coupling size).

Qplus™ - More uptime!

Steelwrist Qplus™ sealing technology is significantly more durable compared to competitor products. This will give you more hours in operation before sealings have to be changed.

Qplus™ - Improved serviceability!

Changing seals in Steelwrist Qplus™ couplings is done fast and easy without need for proprietary and complicated tools.



SAFETY SOLUTIONS

Safe when changing work tools

Customers are increasingly demanding safer coupler solutions - all over the world. At the same time legislators are raising the bar for what is considered "safe".

Luckily accidents are relatively rare but it is still a problem. When we launched the Front Pin Lock technology in 2012 we wanted operator and ground personnel to feel safe during work tool changes, as the operator could see when the work tool is in a safe position.

Thanks to that we are not sensor dependant our solutions works equally well with all types of excavators regardless if they are small, large, new or used.

Today, with thousands of couplers in the field, the result has been a higher safety level and a robust solution cast in steel.

With Steelwrist entrance into the demolition segment the Front Pin Lock was upgraded to a second generation in order to support the heavy demolition work tools, and we are continuously introducing solutions that increase safety even further.



Positive lock indication – intuitive indication with red indicator when the coupler is open and green indicator when the bucket is in a safe position.

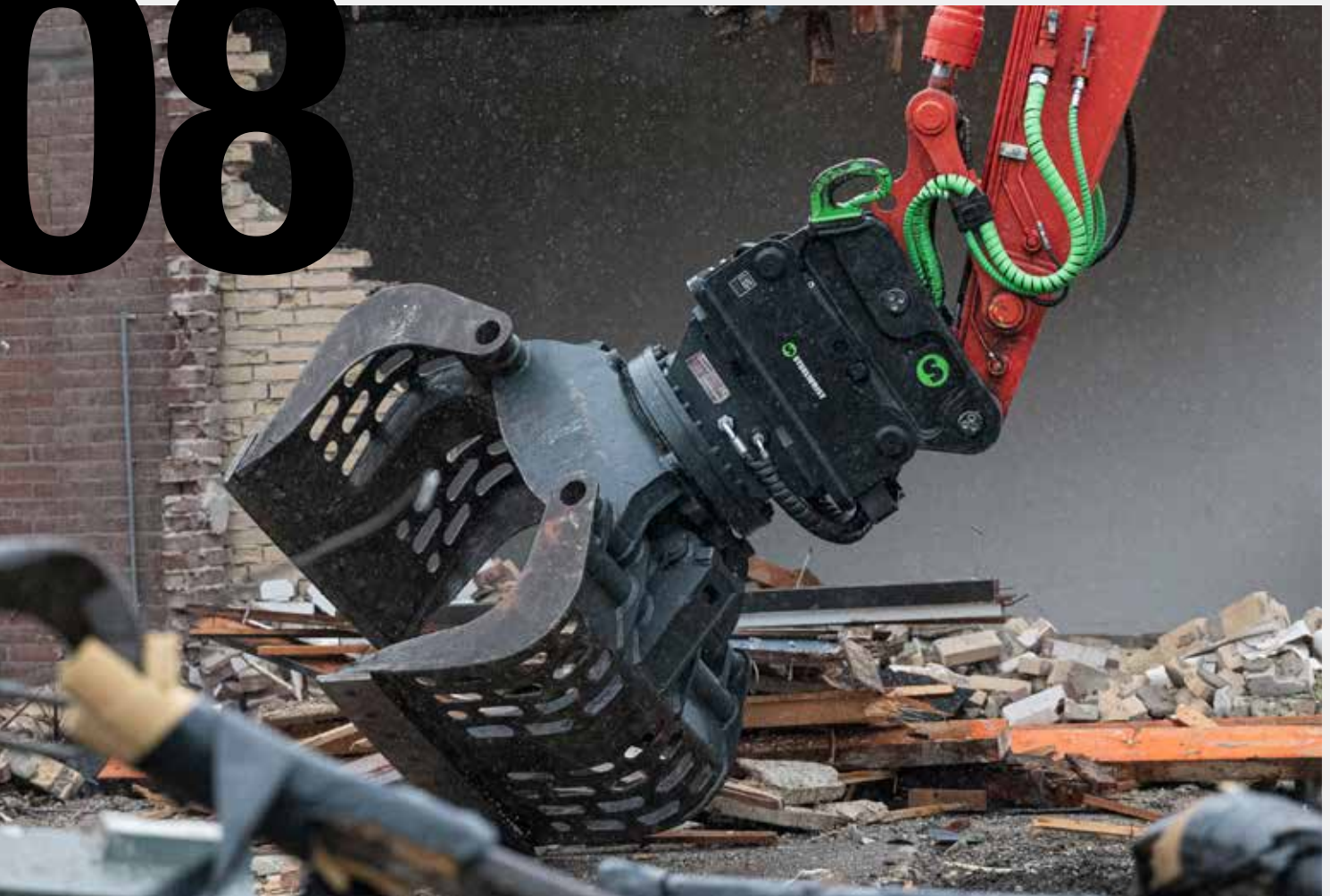

SQ ADAPTORS

Connecting work tools efficiently

The core of the fully automatic quick coupler technology is that it connects the work tool in a safe way, and also connects the hydraulic couplings of the work tool in an automatic way.

Our SQ adaptors are built on the symmetrical Open-S standard and therefore work perfectly with other manufacturers working within the Open-S standard.

All male couplings in the SQ adaptors include the Qplus™ technology, giving your work tool higher flow capabilities and more uptime.

Regardless if you need an SQ adaptor or a weld on adaptor we have the cost effective solution that you need.

Our design philosophy is always to minimize the building height, reduce weight and optimize hose routings for each type of work tool.

Watch our video about SQ Auto Connection System!



Cross section of complete SQ coupler and adapter system mounted to breaker.



Weld on S-type adaptors



Weld on SQ adaptors



Weld on SQ adaptors - long



SQ adaptor plate with manifold



SQ adaptor plate for internal hoses



Pendulum Adaptors



SQ Coupler



SQ Adaptor from above

SQ adaptors including oil couplings compliant with the Open-S standard and therefore works perfectly with other manufacturers couplers having the same dimensions and positions.



SQ FOR GENERAL CONSTRUCTION APPLICATIONS

Enabling new dimensions with SQ Tiltrotator

All Steelwrist tiltrotators from X12 to X32 (7–33 ton excavators) can be equipped with SQ technology. There are two types of configurations when combining Steelwrist tiltrotator with a SQ quick coupler.

Tiltrotator with SQ top and S bottom

SQ on the top side of the tiltrotator (upper coupler) and S on the bottom side of the tiltrotator. This configuration allows for rapid changes directly from the quick coupler (Hydraulic breaker, Tiltrotator). Mechanical work tools beneath the tiltrotator can be changed rapidly, while external hose connections are required for hydraulic powered work tools.

Tiltrotator with SQ top and SQ bottom

SQ on the top side of the tiltrotator (upper coupler) and SQ on the bottom side of the tiltrotator. This configuration allows for rapid changes directly from the quick coupler (Hydraulic breaker, Tiltrotator) as well as beneath the tiltrotator (Sweeper, Compactor).



Watch our video of how quick and easy it is to change work tools with SQ!





Tiltrotators are able to rotate 360 degrees and tilt 45 degrees in each direction with top of the class precision and controllability. This allows you to do the same job faster or do things you could only imagine before.

The combination of using a range of work tools (mechanical and hydraulic powered) beneath the tiltrotator makes it possible to increase productivity and efficiency even further. Customers who started to use tiltrotators never go back.

The tiltrotator is fast becoming a common product in many segments, such as:

- Building and Construction
- Infrastructure
- Ground works
- Utility work (pipes, water and sewage)
- Landscaping
- Road construction
- Demolition
- Recycling
- Railway





SQ FOR DEMOLITION AND RECYCLING APPLICATIONS

Always use the right tools

With every new demolition job comes new challenges, whether it may be location, space, structure, transport, time, resources or other. With Steelwrist SQ technology, your excavator turns into a true tool carrier and provide you with the flexibility and versatility to face these challenges, day in and day out.

Increase productivity and safety by always using the correct tool when crushing, cutting, lifting, sorting, loading and cleaning. No more compromises needed.

Machine Utilization

Remove time thieves. SQ allows operator and machine to work continuously at all times. More work done with less.

Safety

Every powered work tool is designed and optimized for a certain operation or usage. Work safety increases when operators can easily change and use the best tool for the job.

Uptime

Tidy hose installations avoid cuts or damages from re-bars and other sharp debris.

Environment

We can have a big positive effect on the environment by making excavators all around the world significantly more efficient and sustainable. No oil spill during tool change. Effective material sorting at the job site helps recycling and reduces cost in waste handling.

Transport

Easily connect and disconnect the work tool for every machine transport.

SQ adaptors available for all different types of powered work tools used in demolition applications.



Watch our video of SQ couplers in action at a demolition job site!

14

SQ SIZE AND CONNECTIONS, DIMENSIONS AND LOCATIONS

Select specifications for your needs

The hydraulic requirements of the work tools define which coupler size that will be suitable for you. Important questions when selecting the correct quick coupler are:

- What are the work tools flow requirements?
- How many functions do the work tools have?
- Do the work tools require leak oil?
- Machine weight?

Steelwrist representatives will help you with answers about which models and connection setups are suitable for your excavator and work tool.

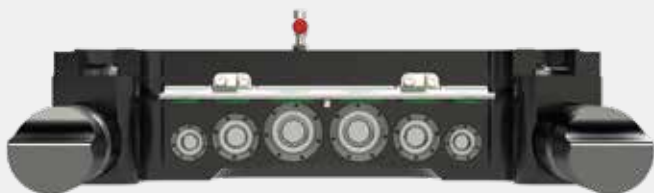

Example of SQ80 H-cylinder with female couplings.

Qplus™ Flow specifications

	Continuous max*	Rec. max
1" Couplings	300 lit/min	450 lit/min
3/4" Couplings	180 lit/min	300 lit/min
1/2" Couplings	90 lit/min	180 lit/min
3/8" Couplings	45 lit/min	75 lit/min
1/4" Couplings	25 lit/min	60 lit/min

*At 5 bar back pressure (male + female)

Example of number of couplings depending on type of work tool*

● Required ○ Not Required

SQ size	Total no of couplings	Coupling sizes	2 functions	2 functions + leak oil	1 function + leak oil	1 function	Machine weight
SQ50	5	2x3/8", 3x1/2"	●●○●●	●●●●●	●○●●●	●○●●●	5-13
SQ60-4	4	2x3/4", 2x1/2"	●●●●	●●●●	●●●○	○●●○	12-20
SQ60-5	5	2x3/4", 2x3/8", 1x1/2"	●●○●●	●●●●●	●○●●●	●○●●●	12-20
SQ65	5	3x3/4", 2x1/2", 1x3/4"	●●○●●	●●●●●	○●●●○	○●○●○	14-22
SQ70	5	2x1", 2x1/2", 1x3/4"	●●○●●	●●●●●	○●●●○	○●○●○	18-33
SQ70/55	6	2x1", 2x1/2", 2x3/4"	●○●●○●	●●●●○●	○●●●○	○○●●○	18-33
SQ80	6	2x1", 2x1/2", 2x3/4"	●○●●○●	●●●●○●	○●●●○	○○●●○	25-43
SQ90	9	4x1", 3x1/2", 1x3/4", 1x3/8"	●●○●●	●●●●●	●●○●●	●●○●●	40-75

*Please verify with your tool manufacturer as the need of connections can vary depending on manufacturer and market standards.



SORTING GRAPPLE

Two-way direction circuit
2 hydraulic lines open/close
2 hydraulic lines for rotation



CONCRETE CRUSHER

Two-way direction circuit
2 hydraulic lines open/close
2 hydraulic lines for rotation
1 leak oil/drain line

DRUM CUTTER

Two-way direction circuit
2 hydraulic lines
1 leak oil/drain line



HAMMER / BREAKER

One way direction circuit
2 hydraulic lines



SQ COUPLER								
Machine Weight [ton]	5–13	12–20	12–20	14–22	18–33	18–33	25–43	40–75
MODEL	SQ50	SQ60-4	SQ60-5	SQ65	SQ70	SQ70/55	SQ80	SQ90
Dimensions [same as]	S50	S60	S60		S70		S80	S90
Weight [kg]	100	135	135	190	245	310	430	750
A. Width [mm]	270	340	340	440	450	550	590	750
B. Length [mm]	430	480	480	530	600	600	670	750
C. Building height [mm]	130	150	150	160	175	210	230	265
D. Lifting hook [ton]	5	5	5	8	8	8	10	15
E. Height [mm]	Max 65	Max 80	Max 80	Max 95	Max 100	Max 100	Max 115	Max 125
F. Diameter grip [mm]	50	60	60	65	70	70	80	90
Pd. Pin diameter [mm]	45–60	60–80	60–80	60–80	60–80	70–90	80–110	100–130
W. Max width dipper arm [mm]	202	250–304	250–304	250–304	250–304	250–304	250–304	250–304
C/C. Pin Distance [mm]	250–380	315–435	315–435	330–460	270–485	370–570	385–585	500–630
Couplings	5	4	5	5	5	6	6	9
3/8"	2	–	2 *	–	–	–	–	1
1/2"	3	2	1	2	2	2	2	3
3/4"	–	2	2	3	1	2	2	1
1"	–	–	–	–	2	2	2	4
Electrical Connector	Yes	Yes	Yes	Yes	Yes	Yes	Yes	Yes

1/4" Germany

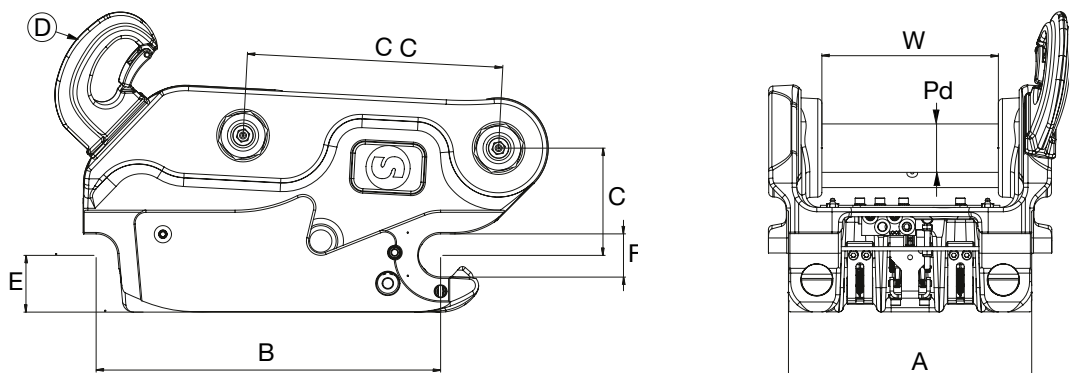

TILTROTATOR (VALUE WITH GRIPPER)						
Machine Weight [ton]	7–12	10–14	12–16	16–20	18–26	25–33
MODEL	X12	X14	X18	X20	X26	X32
Upper coupler	SQ50	SQ50	SQ60-5	SQ60-5 SQ65*	SQ65 SQ70 SQ70/55	SQ70 SQ70/55 SQ80
Attachment coupler Dedicated	SQ50	SQ50	SQ60-5	SQ60-5 SQ65*	SQ65 SQ70 SQ70/55	SQ70 SQ70/55 SQ80
Max tilt angle [Degrees]	± 45	± 45	± 45	± 45	± 45	± 45
Req hydraulic oil flow [l/min]	70–90	80–100	80–100	100–120	100–120	120–140
Max pressure [bar]	210	210	210	210	210	210
Hydraulic extra functions	2(1)	2(1)	2(1)	2(1)	2(1)	2(1)
Weight from [kg]	320 (390)	380 (443)	400 (512)	445 (557)	570 (687)	840 (957)

All dimensions are depending on configuration.

*18–22 tonnes

SQ ADAPTORS BOLT ON								
Machine Weight [ton]	5-13	12-20	12-20	14-22	18-33	18-33	25-43	40-75
WITH MANIFOLD	SQ50	SQ60-4	SQ60-5	SQ65	SQ70	SQ70/55	SQ80	SQ90
Weight [kg]	-	197	198	220	265	267	391	612
A. C/C. Pin Distance [mm]	-	480,25	480,25	530,25	600,25	600,25	670,25	750,25
B. Pin diameter [mm]	-	60	60	65	70	70	80	90
C1. Height [mm]	-	Max 80	Max 80	Max 95	Max 100	Max 100	Max 115	Max 125
D. Pin width [mm]	-	341	341	441	451	551	591	751
E. Adaptor plate width [mm]	Depends on tool							
F. Adaptor plate length [mm]	Depends on tool							
FOR INTERNAL HOSES	SQ50	SQ60-4	SQ60-5	SQ65	SQ70	SQ70/55	SQ80	SQ90
Weight [kg]	100	175	176	188	221	224	327	495
A. C/C. Pin Distance [mm]	430,25	480,25	480,25	530,25	600,25	600,25	670,25	750,25
B. Pin diameter [mm]	50	60	60	65	70	70	80	90
C1. Height [mm]	158	195	195	208,5	255	225	238	273
D. Pin width [mm]	271,5	341	341	441	451	551	591	751
E. Adaptor plate width [mm]	Depends on tool							
F. Adaptor plate length [mm]	Depends on tool							

*Calculated weight without couplings and hoses

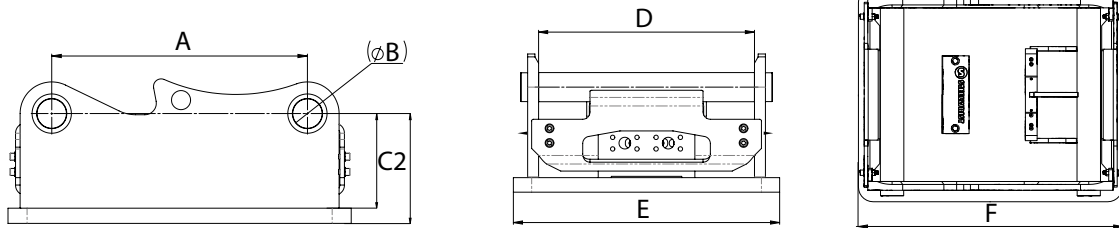

SQ ADAPTORS WELD ON								
Machine Weight [ton]	5-13	12-20	12-20	14-22	18-33	18-33	25-43	40-75
	SQ50	SQ60-4	SQ60-5	SQ65	SQ70	SQ70/55	SQ80	SQ90
A. C/C. Pin Distance [mm]	-	480,25	480,25	530,25	600,25	600,25	670,25	750,25
B. Pin diameter [mm]	-	60	60	65	70	70	80	90
C2. Height [mm]	-	155	155	169	220	190	248	235
F. Adaptor plate length [mm]	-	600	600	661	741	741	837	950
LONG	SQ50	SQ60-4	SQ60-5	SQ65	SQ70	SQ70/55	SQ80	SQ90
A. C/C. Pin Distance [mm]	430,25	480,25	480,25	530,25	600,25	600,25	670,25	750,25
B. Pin diameter [mm]	50	60	60	65	70	70	80	90
C2. Height [mm]	128	105	105	115	135	152	160	235
F. Adaptor plate length [mm]	520,25	797	797	862	940	937	837	950

SQ PENDULUM ADAPTORS								
Machine Weight [ton]	5-13	12-20	12-20	14-22	18-33	18-33	25-43	40-75
MODEL	SQ50	SQ60-4	SQ60-5	SQ65	SQ70	SQ70/55	SQ80	SQ90

COMPACTOR / VIBRO				
Machine Weight [ton]	2-6	5-12	10-22	16-30
MODEL	HC20	HC40	HC60	HC90
Vibration Force [kN]	20	40	60	90
Vibration Frequency [Hz]	38	38	38	38
Weight [kg]	250	387	620	969
Length [mm]	700	850	960	1050
Width [mm]	410	610	700	800
Height [mm]	493	542	595	643
Load Area [m ²]	0,27	0,52	0,67	0,98
Hydraulic Pressure [rec/max]	150/250	150/250	150/250	150/250
Hydraulic Flow [l/min]	30-50	60-80	90-120	120-140
Bracket	SQ50	SQ50, SQ60-4, SQ60-5	SQ60-4, SQ60-5, SQ65, SQ70, SQ70/55	SQ60-4, SQ60-5, SQ65, SQ70, SQ70/55, SQ80

SWEEPER			
Model	SW1000	SW1500	SW2000
Width [mm]	1000	1500	2000
Motor	Dual Motor Direct Drive	Dual Motor Direct Drive	Dual Motor Direct Drive
Mudflap	Standard	Standard	Standard
Flow requirements [l/min]	40-130	40-130	40-130
Integrated parking stand	Yes	Yes	Yes
Brush	Bee-Line		
Bracket	SQ50, SQ60-4, SQ60-5, SQ65, SQ70, SQ70/55, SQ80		

HYDRAULIC PALLET FORK HPF5000			
Machine Weight [ton]	10-33	Width [mm]	1482
Lifting capacity [ton]	5	Weight [kg]	435
Height [mm]	920	Bracket	SQ50-SQ80
Length [mm]	2074		

SERVICE KITS	
Service Box SQ	Tools, couplings (2x) & seals (6x)
DRIVERS BOXES	
Drivers box SQ60	Tools, couplings, seals – 3/4", 1/2", 3/8"
Drivers box SQ60DE	Tools, couplings, seals – 3/4", 1/2", 1/4"
Drivers box SQ65	Tools, couplings, seals – 3/4", 1/2"
Drivers box SQ70-80	Tools, couplings, seals – 1", 3/4", 1/2"



MULTI GRAPPLE					
Machine Weight [ton]	3–6	6–12	8–16	12–18	19–26
MODEL	MG20	MG25	MG32	MG40	MG55
Gripper area [m ²]	0,2	0,25	0,32	0,4	0,55
Gripper reach [mm]	1357	1515	1800	1938	2432
Gripper reach, smallest object [mm]	55	98	98	109	155
Max Load [kg]	3000	5000	6000	7000	10000
Weight [kg]	192	312	410	800	869
Gripper force [kN] [tip against tip]	12,5	17	21	25	38
Height [tip against tip] [mm]	843	919	1101	1127	1309
Height [max open] [mm]	747	781	949	941	1061
Width [mm]	504	594	660	691	795
Bracket	SQ50	SQ50, SQ60-4, SQ60-5	SQ60-4, SQ60-5, SQ65	SQ60-4, SQ60-5, SQ65, SQ70, SQ70/55, SQ80	SQ65, SQ70, SQ70/55, SQ80

STONE AND SORTING GRAPPLE					
Machine Weight [ton]	6–12	8–16	10–20	16–26	22–32
MODEL	SG20	SG25	SG32	SG40	SG55
Gripper area [m ²]	0,2	0,25	0,32	0,4	0,55
Gripper reach [mm]	1250	1707	1830	2204	2716
Max Load [kg]	3000	6000	7000	8000	12000
Weight [kg]	198	377	540	717	1268
Gripper force [kN] [tip against tip]	10	15	20	25	40
Height [tip against tip] [mm]	655	848	1010	1126	1301
Height [max open] [mm]	500	610	863	826	911
Width [mm]	518	600	654	700	1000
Bracket	SQ50	SQ50, SQ60-4, SQ60-5	SQ50, SQ60-4, SQ60-5, SQ65	SQ60-4, SQ60-5, SQ65, SQ70, SQ70/55, SQ80	SQ65, SQ70, SQ70/55, SQ80

FINGER GRAPPLE				
Machine Weight [ton]	6–12	10–18	8–18	16–26
MODEL	FG20-5/FG20-7	FG25-5/FG25-7	FG32-5/FG32-7	FG40-5/FG40-7
Gripper area [m ²]	0,2	0,25	0,32	0,4
Gripper reach [mm]	1389	1552	1823	1956
Max Load [kg]	3000	6000	7000	8000
Weight [kg]	219/242	407/439	630/680	724/785
Gripper force [kN] [tip against tip]	10	15	20	25
Height [tip against tip] [mm]	817	877	1033	1088
Height [max open] [mm]	500	610	863	826
Width [mm]	504	672	698	754
Bracket	SQ50	SQ50, SQ60-4, SQ60-5	SQ60-4, SQ60-5, SQ65	SQ60-4, SQ60-5, SQ65, SQ70, SQ70/55, SQ80

Grapples = Max operating pressure [bar] 250



STEELWRIST
EARTHMOVING EFFICIENCY

**WORLD
DEMOLITION
SUMMIT**
CONFERENCE - AWARDS - NETWORKING

*GOLD SPONSOR
2023 & 2024*

MEMBER OF:



Open-S – the open industry standard for fully automatic quick couplers for excavators.

The purpose of Open-S is to provide global interchangeability between quick couplers, tiltrotators and work tools from different manufacturers.

Read more at www.opens.org